

APPLICATION NOTE 2116

RS-485 Data Interface Gives Isolated, Full-Duplex Operation

A circuit is described that provides fully isolated RS-485 full-duplex data communication with only two integrated circuits (ICs). An internal transformer-coupled isolated supply and internal optocouplers in the data path provide typical isolation to 1600Vrms for 1 minute or 2000Vram for 1 second. Data rates of 250kbaud are achieved with internally slew-rate-limited circuits or to 2.5Mbaud with non-slew-rate limited circuits, depending upon choice of available ICs.

The simple RS-485 circuit of **Figure 1** provides full-duplex communications (simultaneous transmission and reception) with only two essential packages (IC2 and IC3). Its balanced and differential data lines are necessary for high-noise environments or for long-distance transmission between a computer and its peripherals. Such transmissions are difficult, if not impossible, with the single-ended circuitry of an RS-232 transceiver.

The RS-485 standard allows for bidirectional, multi-point, party-line communications, with data rates to 10M bits/second (10Mbps) and line lengths to 1200 meters. Differential transmission provides noise immunity. The circuit shown features controlled-slew-rate drivers that minimize EMI and the reflections caused by improperly terminated cables. It also enables error-free transmissions to 250kbps. To achieve data rates to 2.5Mbps, substitute a full-slew-rate MAX1480A for IC2, a MAX485 for IC3, and R2?5 values per **Table 1**.

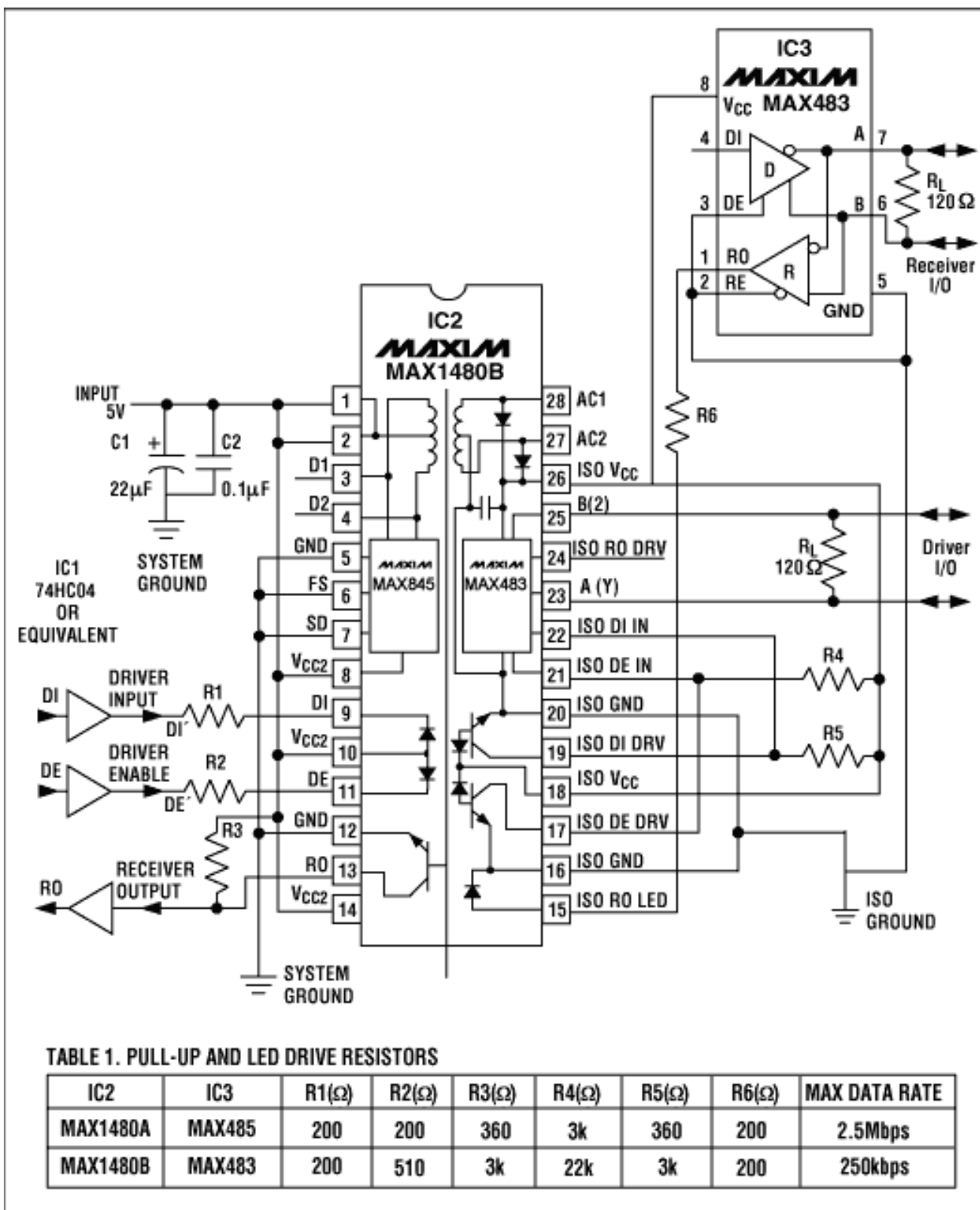

Figure 1. IC2 and IC3 provide full-duplex data communications for cable lengths as long as 1200 meters.

IC2 is a complete half-duplex interface that includes transceivers, optocouplers, a power driver, and a transformer. The optocouplers transmit digital signals across the internal isolation barrier, and the center-tapped transformer transmits power across the barrier from its logic (non-isolated) side to its isolated side.

IC3, powered by the isolated VCC, upgrades the half-duplex operation of IC2 to full duplex using IC2's own dedicated

optocouplers. Pin 3 must be tied low to disable IC3's driver, and pin 4 should be left floating. The driver outputs for IC2 and IC3 exhibit high impedance when DE is low; bringing DE high enables the outputs to function as line drivers.

The isolation barrier in IC2 typically withstands 1600Vrms for one minute or 2000Vrms for one second. Any TTL/CMOS-logic family can drive the IC2 digital inputs through a series resistor. With resistive pull-ups, the receiver outputs can drive any such logic as well. IC2's isolated outputs meet all RS-485 specifications.

More Information

MAX1480A:	QuickView	-- Full (PDF) Data Sheet	
MAX1480B:	QuickView	-- Full (PDF) Data Sheet	
MAX253:	QuickView	-- Full (PDF) Data Sheet	-- Free Samples
MAX483:	QuickView	-- Full (PDF) Data Sheet	-- Free Samples
MAX483E:	QuickView	-- Full (PDF) Data Sheet	-- Free Samples
MAX485:	QuickView	-- Full (PDF) Data Sheet	-- Free Samples
MAX485E:	QuickView	-- Full (PDF) Data Sheet	-- Free Samples